

# Specialist Door Products



- Armourguard
- Fire Guard
- Q Door
- S Door
- C Door
- VR Door
- EV Curtain
- Crash Door
- Steel Security Door
- Roller Shutter Personnel Door
- Securo Mesh
- Securo Bar



# Armourguard Industrial Range



Armourguard C1



Armourguard F1

## Features

- Steel construction
- Custom made and adaptable in design for site constraints

## Security

- Variable level of security through locking device choice
- Automatic locking

## Operation

- Hand chain operation is spring assisted to aid movement
- Electric operation can be powered by single or three-phase motor
- Various control and operator units to automate and secure closing
- Manual override system available

## Model Variation and Strengths

- Versatile in construction to span and secure larger openings
- Models available in 18, 20 and 22 gauge steel lath
- Models in flat (100mm) or curved (76mm) lath sections
- Perforated and punched areas available when ventilation or vision is required
- Twin Skin insulated lath available for thermal insulation (Model F1/F2 100mm flat lath)
- Wind resistant guide and end locking units for exposed/vulnerable applications
- Available with integrated personnel door (Wicket door)

## Presentation

- Galvanised as standard
- HP200 Plastisol coated
- Polyester powder coat finish (Full colour range available)



Armourguard F1Thermal Insulated

# Fire Guard



Fire Guard FG01



Fire Guard FG01 - Under Test Conditions

## Common Use

- Kitchen serveries
- Industrial areas where fire protection is required

## Features

- High security 2-4 hour fire resistant roller shutter
- Automatic closing (various options available)
- Certified fire protection product

## Operation

- Electrically operated by single or 3 phase industrial motor
- Solenoid release system activated by a 24volt signal, self closing rolling shutter with controlled descent
- Hand chain override
- Push button control unit
- Fusible link backup can be incorporated to self close, when local temperature exceeds 72°C

## Presentation

- Galvanised as standard
- Polyester powder coat finish (full colour range available)

# Rolling Security Systems Technical Drawing Detail

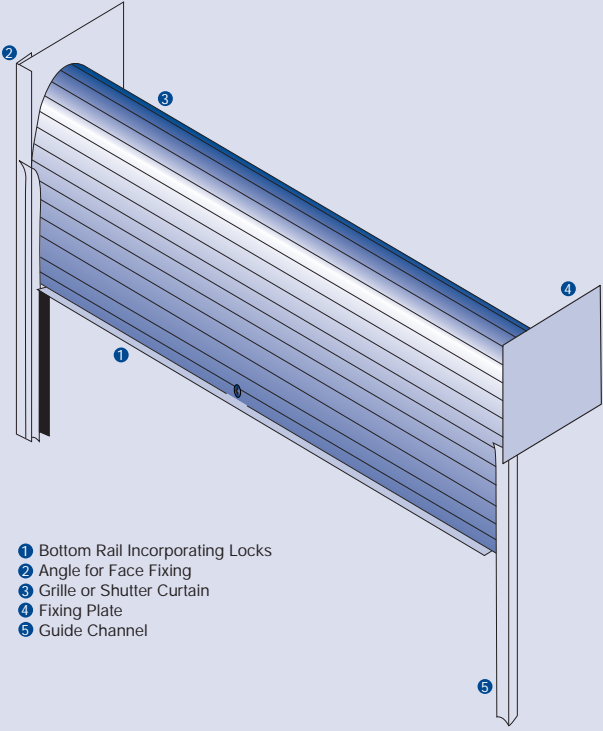

- 1 Bottom Rail Incorporating Locks
- 2 Angle for Face Fixing
- 3 Grille or Shutter Curtain
- 4 Fixing Plate
- 5 Guide Channel

# Industrial and Fire Guard Installation Options

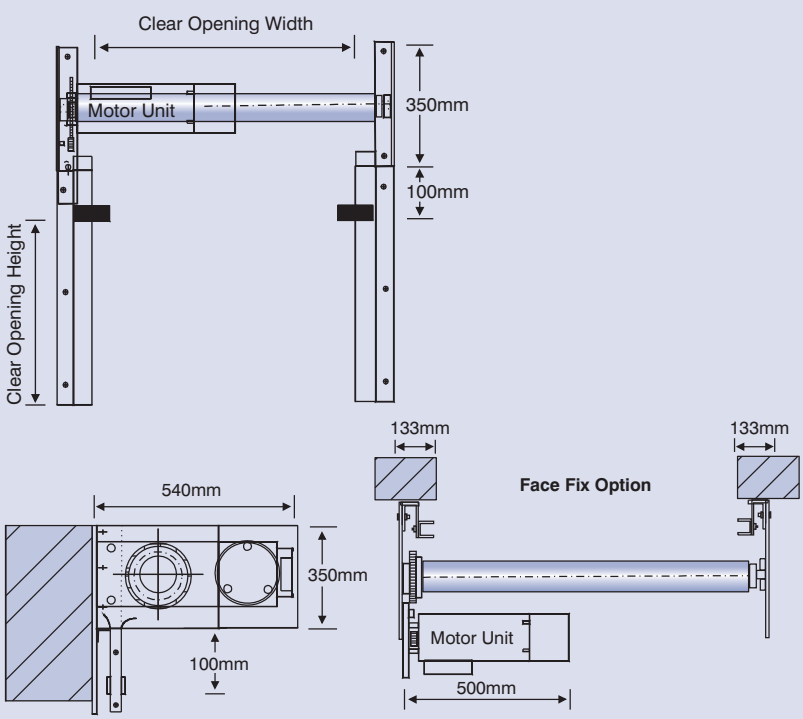

Stated measurements may vary dependant on site requirements.

# Industrial Rolling Security Systems Installation Options

Installation & Space Requirements For Chain Operated Industrial Roller Shutters

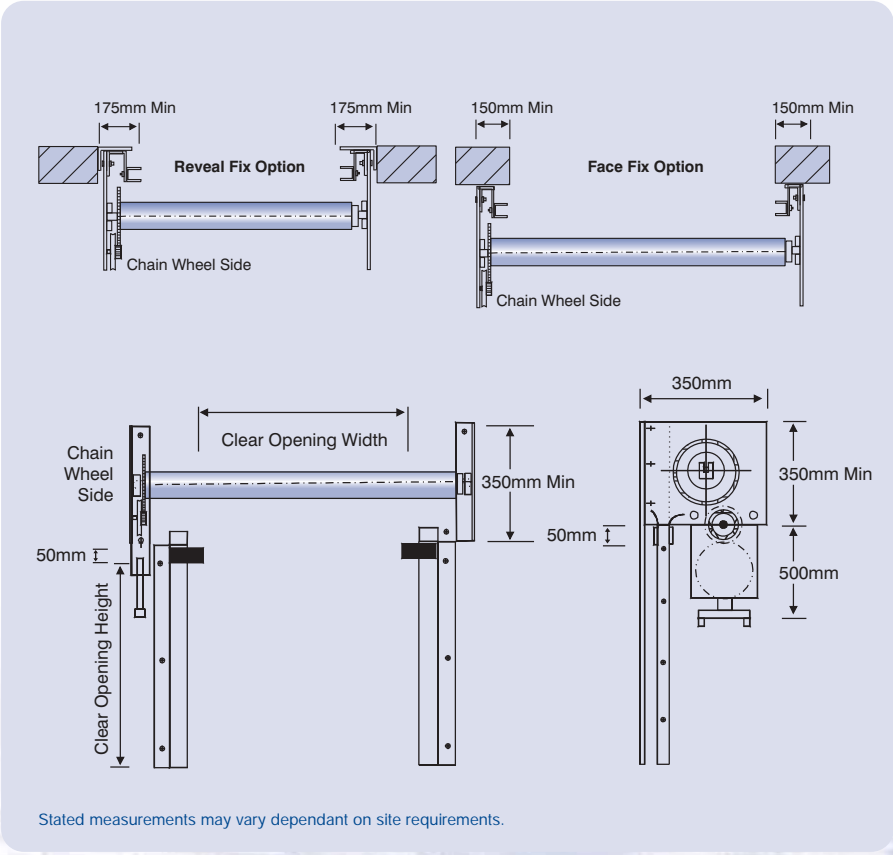

Installation & Space Requirements For Electrically Operated Industrial Roller Shutters

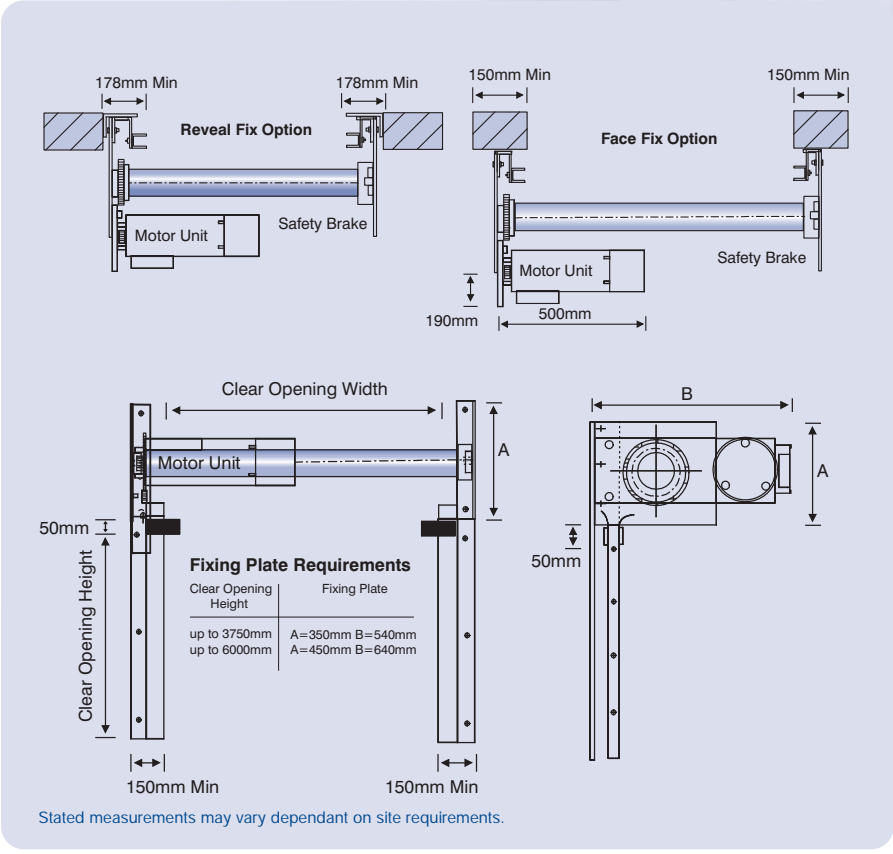

# Q Door



## Features

- Folding insulated panel door
- Extremely low maintenance costs

## Strengths

- Anti crush safety system as standard on electrically operated doors
- The door leaf is constructed from a composite of polyurethane and a steel reinforced frame between aluminium skins

## Operation

- Manual hand operation
- 3 phase electrically operated with push button control unit
- Different leaf configurations to suit individual requirements

## Model variations

- Various window shapes and sizes to alter appearance

## Presentation

- PVC 2 as standard
- Range of seven plastisol colours
- Computer aided presentation of Q Door is available on request

## Insulated to European Standards

- The Q Door F4 sealing system complies with top European requirements, but at three times the pressure!

\* (Figures: The top European class 3 for air leakage describes air leakage (T Value) as at best  $1.5\text{m}^3/\text{m}^2/\text{h}$  at 50 Pa pressure. i.e  $1.5\text{m}^3/\text{h}$  to 150 Pa)

# Q Door Technical Detail

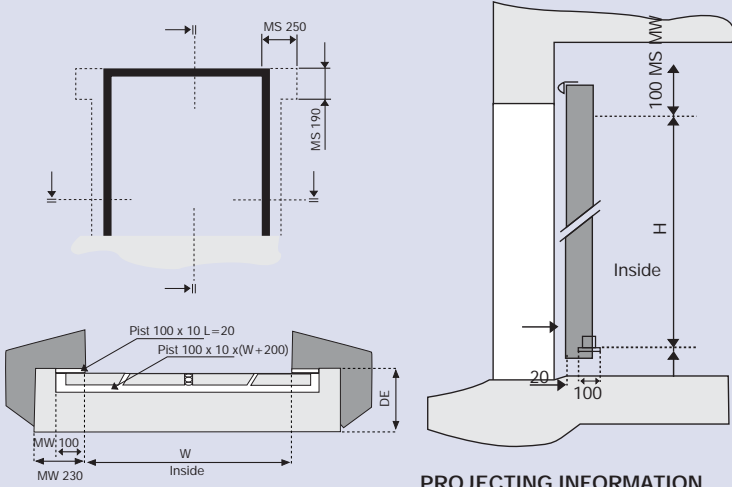

Optional Frame Design

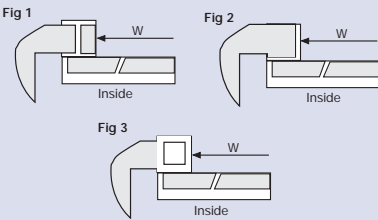

Optional Frame Design

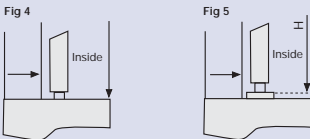

## PROJECTING INFORMATION Q-DOOR FX and Q-DOOR IQ FX

Steel frames for welded assembly of manual 2,3 and 4 sectioned, inward opening, overlap fitted sandwich designed folding door.

DE = depth for open door  
=  $W / \text{No. of sections} + 150\text{mm}$

Width for doorsill steel =  $W + 200\text{mm}$

W and H measurements: + 5mm

Frame and doorsill should be straight, square and in-line.

MW = minimum steel width.  
MS = minimum space.

All necessary frame steel is not usually included in the door delivery.

DIVISION Type / No. of sections	DAYLIGHT AREA (mm)		
	Max. width (w)	Min. width	(H) Max. height
F2: 2 sections	2403	1435	6000
F3: 3 sections	3540	2100	6000
F4: 4 sections	4774	2835	6000
F5: 5 sections	5876	3500	6000
F6: 6 sections	7004	5000	6000
F7: 7 sections	8000	6900	6000
F8: 8 sections	9000	8000	6000
F9: 9 sections	10000	9000	6000
F10: 10 sections	11100	10000	6000

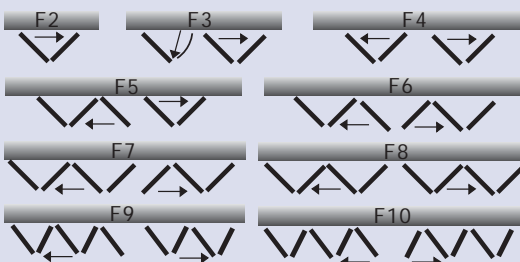

# S Door



## Common Use

- Industrial door

## Features

- Vertical opening sectional door
- 610mm x 40mm composite panels using 0.5mm thick hot dipped zinc coated steel

## Operation

- The S Door is counterbalanced, using minimal effort to ensure the smooth running of doors
- HAG offer a range of manual & automatic operations, including a large number of safety features

## Model Variations and Strengths

- The panels are bonded together using a CFC free foam which has a density of 40kg/m<sup>3</sup>. The panel itself gives a "U" value of 0.45 W/m<sup>2</sup> K
- The panel also has a single figure weighted sound reduction of [Rw] 25 dB
- A formed tongue and grooved hinged joint incorporating a neoprene seal running the full length of the panel to give excellent weather resistance
- Optional extras - double glazed windows, Integral personnel doors in main door, door safety furniture
- Maximum size: 8000mm x 6000mm

## Presentation

- Plastisol XL200 forte or polyester coating to the external face in an extensive range of colours, internal RAL 9010
- Factory paint finish to either internal or external face to any BS or RAL colour





# C Door



## Common Use

- Industrial door

## Features

- Galvanised steel horizontal sliding folding door
- Suspended from Lintel with floor track
- Maximum width 14000mm

## Security

- Hasp and staple padlocking facility is fitted to the inside or outside to enable positive locking from either side as standard

## Operation

- Manual
- Electric operation via single or three phase motor
- In the event of an electrically operated door meeting an obstruction when operating, the torque limit operates the micro switch to switch off the mains supply to the motor

## Model Variations and Strengths

- The door comprises of a galvanized steel collapsible gate having vertical picket interconnected by rectangular steel bars acting on the "lazy tong" principle
- Doors can be arranged to bunch to either one or both sides of an opening

## Optional Extras

- An alternative lever lock system can be incorporated.
- Viewing panels - with toughened glass
- Railway lines - special track to allow railway line through the opening
- Runway beams - cut out section to allow overhead beams though the door
- Sumps - water drainage for bottom track

# VR Door



## Common Use

- Temperature controlled rooms or areas where thermal exchange between inside and outside areas to be minimised

## Features

- High speed vertical PVC door
- The VR Door is a rip proof double layered PVC reinforced vertical door.
- Minimal maintenance required
- High speed opening and closing
- Temperature resistance -25°C to +75°C

## Operation

- Opening speed: approx 1m/sec
- Electric operation HP 1 engine, self braking, isolated in class F; Reducer 140 rpm
- Control panel with open/close/stop function 1 no yellow aerial blinking light
- Aerial device for manual opening in case of current failure

## Model Variations and Strengths

- The frame is a metallic structure in a self bearing galvanised steel, the structure acts as a frame and as a guide track for the PVC sheet
- The canvas is a rip proof double layered sheet, made with a series of horizontal pockets into which metal reinforced bars are placed, which strengthen the door preventing accidental opening due to strong gusts of wind
- Vision panels transparent porthole windows allow personnel to see through the door before transit

# EV Curtain

## Common Use

- Industrial units, doorways cold stores

## Features

- PVC vertical hanging strip curtain
- The recommended temperature range in use is -5°C to +60°C
- Cost effective way in protecting from the external elements
- Controls the spread of airborne pollutants



## Model Variations and Strengths

- The thickness of the curtain ranges from 2mm to 4mm, 200mm wide to 400mm wide strips
- The overhead rail is supported by a galvanised or stainless steel frame

## Presentation

- Clear midsection as standard with optional colours for end sections if required

## Over Head Fixing Options

- Removable strips
- Swing strips
- Side sliding strips

# PVC Crash Door

## Common Use

- Internal door ways where traffic and goods pass through

## Features

- Durable PVC swing door to resist impact abuse (pallets/carts)
- Minimal maintenance required
- Good for temperature control

## Strengths

- Transit takes place in both directions and for this reason the opening/closing can take place in two different ways according to your request
- Protective rubber strips can be applied upon request in order to give protection against abrasion and scratching and in this way prolonging the doors working life



## Operation

- Manually - With a spring-loaded mechanism which will close both door-sheets automatically after transit
- Semi-automatically - A cylinder pushes the doors open and a spring loaded mechanism will close them afterwards

# Steel Security Door

## Description

- HAG Steel Door, hinged steel fire door

## Common use

- Commercial and Industrial

## Finish

- Standard - light grey primer options - wet sprayed colour top coat

## Dimensions

- Standard sizes available
- Bespoke sizes available on request

## Flush Door

- Type FD - multi-purpose steel door
- FIRE CLASS: 120 minutes in accordance with BS476 part 20 and 22



## Fire Rating

- This doorset achieves a rating of 120mins in accordance with the criteria laid down in BS476 part 20 and 22

## Standard Fitout

- Single: prepared for modular mortice lock
- Strengthen for closure / panic hardware
- Double: as above with the addition of flush bolts to inactive leaf

## Sound Reduction

- When fitted with weather seal and threshold, the doorset will achieve a rating of 30Db (mineral wool infill only)

## Optional Extras

- Panic bolts
- Panic latches
- Closers
- Vision panels
- Louvres
- Spy holes etc

## Door Blade

- Overall thickness: 55mm
- Material: 1.2mm galvanised steel skins
- Insulation core: honeycomb (mineral wool optional)
- Design: the door skins are folded and spot welded. The door leaf has a high surface finish with accurate sizing



## Handing

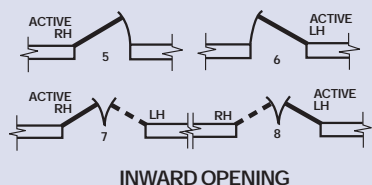
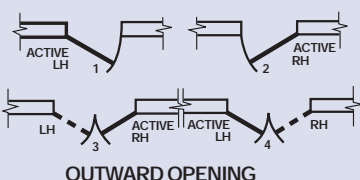

# Roller Shutter Personnel Door



## Features

- Secure roller shutter personnel wicket door
- Energy saving when personnel entering and exiting industrial premises
- Used in conjunction with industrial roller shutter

## Security

- Standard latch locking system
- Additional locking systems available on request

## Model Variations and Strengths

- Available in two sizes
- Standard size: 565mm x 1605mm (clear opening)
- Euro size: 800mm x 1830mm (clear opening)

## Presentation

- Framework primer finished with galvanised laths as standard
- Polyester powder coat finish available

# Seceuro Mesh



## Common Use

- Public, commercial and private building windows

## Features

- High security near invisible protective barrier
- Cost effective protection for vulnerable windows
- Ultimate low maintenance

## Security

- A 2mm steel mesh held in an aluminium frame with a matrix of 4mm diameter perforations providing 60% light through
- The perforated design gives the appearance of tinted glass which is unobtrusive and can blend into the look of the building
- When fitted to steel, brick, concrete or hard wood timber, Seceuro Mesh is compliant with LPS 1175 Level 1

## Presentation

- The aluminium frame can be powder coated in any RAL or BS colour available



# Seceuro Bar



## Common use

- Internal office windows

## Features

- Removable window bars
- The award-winning Seceuro Bar system
- Suitable for installation in a horizontal or vertical format

## Security

- The award-winning Seceuro Bar system features anti-cut steel bars which are securely locked into position to protect vulnerable window openings, but can be released from the inside to allow total vision or maintenance of windows
- Suitable for installation in a horizontal or vertical format, Seceuro Bar is finished to a high standard and delivers security which is quick and easy to install, yet highly effective in a range of locations

## Presentation

- White as standard
- RAL / BS powder coat options available on request



# Associated Products and Service Range

## Steel Fabrication

HAG offer a wide range of tailor made steel fabricating services to specification

## Iron Bars/Grilles

Fixed mild steel protective grilles manufactured to insurance specification

## Timber Shutter

Wooden Rolling Shutters constructed from various timber types

## Clear Polycarbonate Rolling Shutters

Solid maximum vision systems for retail premises

## Powder Coating

Full range of RAL and BS colours. Service First accreditation. Range of pre-treatment systems.

## Ram Posts

Fixed or removable hollow steel sections providing security against vehicle intrusion

## Cabinet Shutters

Rolling shutters designed to customer specifications

## Planned Maintenance

Increase operational life expectancy for your product

## Installation

All products are installed in compliance with BS EN 12635 (2002)

## 24 Hour Repair

Emergency repairs 24 hours a day, 365 day per year





HAG design, manufacture and install a full range of property protection systems for domestic commercial and industrial applications. Our dedicated Customer service teams ensure complete satisfaction by providing comprehensive support from ordering to owning HAG products.

After care benefits:

- Nationwide service
- 24 hour repair help line
- Service contracts



## Products and Services Range

### Home & Office Security

Retractable Security Gates, Window and Door Security Shutters (Built-in/Built-on), Roller Garage Doors

### Rolling Security Systems

Armourguard Range, Alishield Range, Diamond Roll Grille, Alulink Grille

### Specialist Door Products

Armourguard Industrial Range, Fire Guard, Q Door, Steel Door, Wicket Door

### Specialist Retail Security Systems

Clear Guard, Ali Glyde

### Services

24 Hour Repair, Installation Services, Maintenance Contracts

### Powder Coating

Bespoke inhouse Powder Coating service

### Associated Products

Steel Fabrication, Iron Bars, Timber Shutters, Clear Polycarbonate Rolling Shutters, Ram Posts, PVC Insulating Strip Curtain



Eden Project. St Austell Cornwall

NATIONAL ADVICE LINE  
0117 965 4888

1 Oak Lane Fishponds Bristol BS5 7UY Tel: 0117 965 4888 Fax: 0117 965 7773

email: [info@hag.co.uk](mailto:info@hag.co.uk) website: [www.hag.co.uk](http://www.hag.co.uk)

DISCLAIMER: HAG operates a policy of continuous improvement. Product specification may change and it is advisable to consult with HAG technical advisors before specifying or ordering.